



# UL INSTALLATION INSTRUCTION & MAINTENANCE MANUAL FOR CRYSTALLINE SOLAR PHOTOVOLTAIC MODULE

REVISIONS					CNPV Dongying Solar Power Company Limited, China	
REV	ECO/NPA	DESCRIPTION OF CHANGE	CHK'D/DATE	APP'D/DATE	TITLE:	
A	08-2008	Release to Market for 72cell Module with 125x125mm Mono Crystalline	Jane Liu 21 <sup>st</sup> Aug 2008	Chaudary 21 <sup>st</sup> Aug 2008	<b>UL INSTALLATION INSTRUCTION &amp; MAINTENANCE MANUAL FOR CRYSTALLINE SOLAR PHOTOVOLTAIC MODULE</b>	
B	09-2008	Added 60cell Module with 156x156mm Mono and Poly Crystalline	Jane Liu 12 <sup>th</sup> Sep 2008	Chaudary 12 <sup>th</sup> Sep 2008		
C	06-2009	Added 72cell Module with 156x156mm Mono and Poly Crystalline	Yang Xiaowu June 1 <sup>st</sup> , 2009	Chaudary June 1 <sup>st</sup> , 2009	SPECIFICATION NO: <b>CNPV-PS-M-S0010</b>	PART NO: <b>N/A</b>
D	10-2009	Update of 72-156M module	Yang Xiaowu Oct. 30 <sup>th</sup> , 2009	Chaudary Oct. 30 <sup>th</sup> , 2009	DRAWN BY: <b>Chaudary</b>	
E	12-2009	Add description of grounding system	Yang Xiaowu Dec. 10 <sup>th</sup> , 2009	Chaudary Dec. 10 <sup>th</sup> , 2009	SHEET 1 OF 1	
F	01-2010	Add 54cell Module with 156x156mm Mono and Poly Crystalline	Yang Xiaowu Jan. 4 <sup>th</sup> , 2009	Chaudary Jan. 4 <sup>th</sup> , 2009		

		<b>TECHINICAL SPECIFICATION</b>	
<b>TITLE:</b> UL INSTALLATION INSTRUCTION & MAINTENANCE MANUAL FOR THE CRYSTALLINE SOLAR PHOTOVOLTAIC MODULE		<b>SPEC. NO.:</b>	CNPV-PS-M-S0010
		<b>REVISION:</b>	F
		<b>EFFECTIVE DATE:</b>	Jan. 2010
<b>AUTHOR(S):</b>	B V Chaudary		Page 1 of 12

## 1. INTRODUCTION

This installation instruction manual provides information about CNPV Crystalline Solar Photovoltaic Modules. CNPV Dongying Photovoltaic Power Company Limited has a history of successful innovation within the Solar Industry. The company was founded in 2006 and has made significant investments in research and development, creating over 10 patents during the company' history.

The company has several fully integrated product lines including ingots, casting, wafers, Cells and Modules of Mono and Polycrystalline Silicon Solar Photovoltaic (SPV) Modules and those products are also exported to overseas markets. With an experienced international management team and a strong reputation for innovation, CNPV is one of the leaders in China's Solar Energy Sector and provides the highest quality SPV Modules in a range of sizes designed to meet the requirements of the most demanding energy and power users worldwide.

## 2. POWER MODULE

CNPV Solar Photovoltaic Modules consist of a series of electrically interconnected crystalline silicon solar cells. Which are permanently encapsulated between a low iron toughened glass superstrate and substrate. The entire laminate is secured within an anodized aluminum frame for structural strength; ease of installation and to protect the cells from the most severe environmental conditions.

## 3. APPLICATIONS

CNPV SPV Modules are a highly reliable, virtually maintenance-free direct current (DC) power source, designed to operate most efficiently in sunlight. CNPV series Modules are ideal to power remote homes, recreational vehicles, water pumps, telecommunication systems and many other applications either with or without the use of storage batteries.

## 4. PERMIT

Before installing your system, contact local authorities to determine the necessary permit, installation and inspection requirements.

## 5. CLIMATE CONDITION

Install the CNPV Solar Photovoltaic Crystalline series Modules in the following conditions:

- Ambient temperature: -20°C to +40°C.
- Operating temperature: -40°C to +85°C.
- Storage temperature: -40°C to +40°C,
- Humidity: below 85RH%
- Wind pressure: below 50.12lb / ft<sup>2</sup> (2400Pa).
- Snow Load Pressure: below 112.76lb / ft<sup>2</sup> (5400Pa).
- Corrosion resistance: except for corrosive salt area and sulfurous area.

<b>CNPV<sup>POWER</sup></b>		<b>TECHINICAL SPECIFICATION</b>	
<b>TITLE:</b> <b>UL INSTALLATION INSTRUCTION &amp; MAINTENANCE MANUAL FOR THE CRYSTALLINE SOLAR PHOTOVOLTAIC MODULE</b>		<b>SPEC. NO.:</b>	<b>CNPV-PS-M-S0010</b>
		<b>REVISION:</b>	<b>F</b>
		<b>EFFECTIVE DATE:</b>	<b>Jan. 2010</b>
<b>AUTHOR(S):</b>	<b>B V Chaudary</b>	<b>Page 2 of 12</b>	

## 6. SITE SELECTION

In most applications, CNPV SPV Modules should be installed in a location where they will receive maximum sunlight throughout the year. In the Northern Hemisphere, the Module should typically face south, and in the Southern Hemisphere, the Modules should typically face north. Modules facing 30 degrees away from true South (or North) will lose approximately 10 to 15 per cent of their power output. If the Module faces 60 degrees away from true South (or North), the power loss will be 20 to 30 per cent.

When choosing a site, avoid trees, buildings or obstructions, which could cast shadows on the solar photovoltaic Modules especially during the winter months when the arc of the sun is lowest over the horizon. Shading causes loss of output, even though the factory fitted bypass diodes of the SPV Module will minimize any such loss.

Do not install the SPV Module near naked flame or flammable materials.

Do not install the SPV Module in a location where it would be immersed in water or continually exposed to water from a sprinkler or fountain etc.

## 7. MODULE TILT ANGLE

CNPV SPV Modules connected in series should be installed at same orientation and angle. Different orientation or angle may cause loss of output power due to difference of amount of sunlight exposed to the Module.

CNPV SPV Modules produce the most power when they are pointed directly at the sun. For installations where the SPV Modules are attached to a permanent structure, the SPV Modules should be tilted for optimum winter performance. As a rule, if the system power production is adequate in winter, it will be satisfactory during the rest of the year. The Module tilt angle is measured between the solar Modules and the ground (Figure 1). Optimal tilting of SPV Module is almost the same as the latitude of installation location.

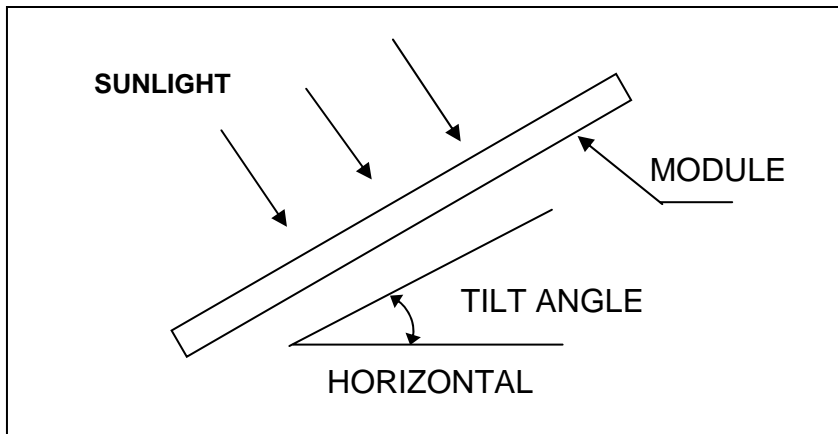

**Figure 1 SPV Module Tilt Angle**

		<b>TECHINICAL SPECIFICATION</b>	
<b>TITLE:</b> <b>UL INSTALLATION INSTRUCTION &amp; MAINTENANCE MANUAL FOR THE CRYSTALLINE SOLAR PHOTOVOLTAIC MODULE</b>		<b>SPEC. NO.:</b> <b>CNPV-PS-M-S0010</b>	<b>REVISION:</b> <b>F</b>
		<b>EFFECTIVE DATE:</b> <b>Jan. 2010</b>	
<b>AUTHOR(S):</b>	<b>B V Chaudary</b>	Page 3 of 12	

## 8. MOUNTING AND NOTES

Systems should be installed by qualified personnel only. It involves electricity, and can be dangerous if the personnel are not familiar with the appropriate safety procedures.

The Module frame is made of anodized aluminum, and therefore corrosion can occur if the Module is subject to a salt water environment with contact to a rack of another type of metal (Electrolysis Corrosion). If required, PVC or stainless steel washers can be placed between the SPV Module frame and support structure to prevent this type of corrosion. Module support structures that are to be used to support SPV Modules at correct tilt angles should be wind and snow load rated for use by the appropriate local and civil codes prior to installation.

CNPV SPV Modules can be mounted as following method:

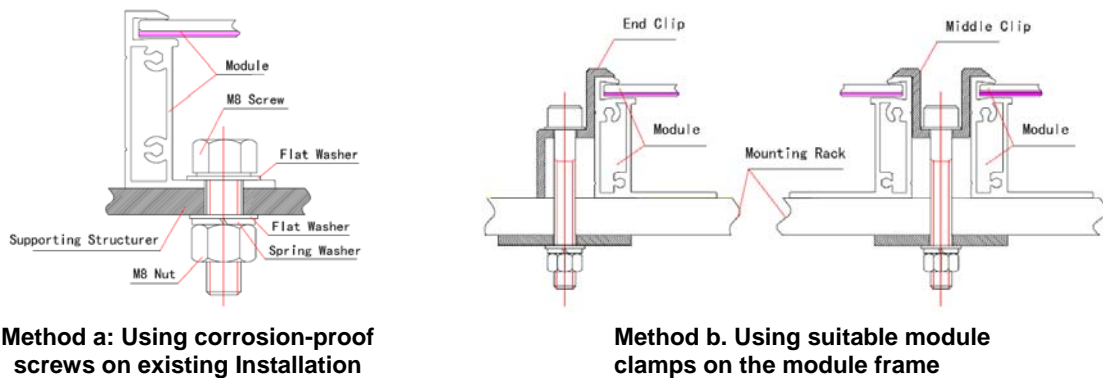

**Figure 2 Mounting Method a and b**

- Using corrosion-proof screws (M8) on the existing installing holes (see drawing 1, 3, 5 & 7) in the Module frame. The frame of each Module has 4 or 8 mounting holes (12mm\*9mm) used to secure the Modules to supporting structure. The Module frame must be attached to a supporting rack using M8 stainless steel hardware together with spring washers and flat washers in four places symmetrical on the SPV Module. See method a of figure 2. The applied torque is about 8 Newton-meters.
- Using suitable Module clamps on the Module frame, see figure 2, method b. The module frame must be attached to supporting rack using M8 stainless steel hardware together with corrosion-proof clips in four places on the SPV module. See drawing 2, 4, 6 & 8, *with clamping clip*, for positioning of clamping clips. The applied torque is about 8 Newton-meters.

### NOTES:

- The Module clamps must not come into contact with the front glass and must not deform the frame. Avoid shadowing effects from the Module clamps and the insertion systems. It is not permitted to modify the Module frame under any circumstances. Recommended distance between 2 Solar Modules is 5mm considering linear thermal expansion of the Module frames.
- Clearance between the Module frame and mounting surface may be required to prevent the junction box from touching the surface, and to circulate cooling air around the back of the Module.

<b>CNPV<sup>POWER</sup></b>		<b>TECHINICAL SPECIFICATION</b>	
<b>TITLE:</b> <b>UL INSTALLATION INSTRUCTION &amp; MAINTENANCE MANUAL FOR THE CRYSTALLINE SOLAR PHOTOVOLTAIC MODULE</b>		<b>SPEC. NO.:</b>	<b>CNPV-PS-M-S0010</b>
		<b>REVISION:</b>	<b>F</b>
		<b>EFFECTIVE DATE:</b>	<b>Jan. 2010</b>
<b>AUTHOR(S):</b>	<b>B V Chaudary</b>	Page 4 of 12	

(3) The Modules are not designed for integral mounting as part of a roof or wall. The mounting design may have an impact on the fire resistance. If the Modules are to be installed on the roof or wall of a building, the fire resistance of roof covering or wall should be rated for the application. Here the standoff method or the rack method is recommended. The Modules are supported parallel to surface of the building wall or roof. Clearance between the Module frames and surface of the wall or roof is required to prevent wiring damage and to allow air to circulate behind the Module. The recommended stand-off height is 115mm, if other mounting means are employed this may affect the UL Listing. Any slope less than 5in/ft (127mm/305mm) required to maintain a fire class rating. Do not mount SPV Module in such way that the drain holes of SPV Module are intended to block up.

(4) Do not step on the Module, although SPV Modules are quite rugged, the glass can be broken (and the Module will no longer work properly) if it is dropped or hit by tools or other objects.

(5) The modules have been evaluated by UL for mounting using the 4 provided mounting holes in the frame.

(6) The modules have been evaluated by UL for a maximum positive or negative design loading of 30 lbs/ft<sup>2</sup>.

## 9. GROUNDING

All Module frames and mounting racks must be properly grounded in accordance with the National Electrical Code. Proper grounding is achieved by connecting the Module frame(s) and structural members contiguously one to another using a suitable grounding conductor. The grounding conductor or strap may be copper, copper alloy, or other material acceptable for use as an electrical conductor per NEC. The grounding conductor must then make a connection to earth using a suitable earth ground electrode.

CNPV recommend Grounding Clip Assembly 1954381-2 (*UL category & file No.: KDER.E69905*) from *Tyco Electronics* for grounding. Installation process is as follows:

(1) Find the grounding hole in the frame with 'GR' mark.

(2) Place the grounding clip onto the frame, making sure that the screw straddles the grounding hole. Using a No.2 cross-recessed screwdriver, thread the screw into the hole until the head is flush with the base and the base is flush with the frame, then tighten the screw with another 1/4 to 1/2 turn. Recommended torque is between 2.3 and 2.8Nm.

(3) Thread the hex nut onto the end of the screw, then using a 3/8-in. wrench, tighten the nut.

(4) Insert the wire into the wire slot. Press down on both ends of the wire (the wire slot will cause the wire to form a slight curve).

(5) Manually, or using channel lock pliers, push the slider over the base until it covers the base. This will terminate the wire.

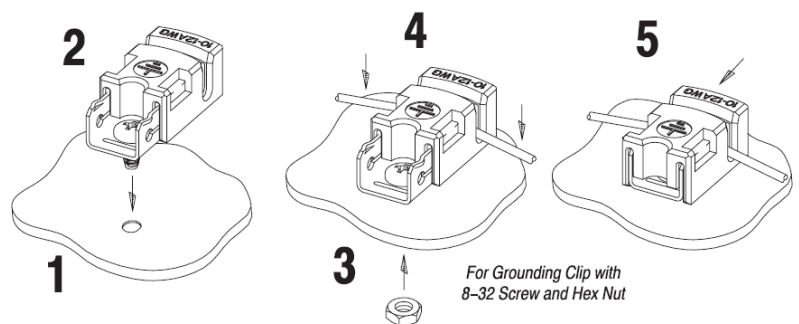

**Figure 3 Schematic drawing for SPV Module**

The rack must also be grounded unless they are mechanically connected by nuts and bolts to the grounded SPV Modules. The array frame shall be grounded in accordance with NEC Art250.

		<b>TECHINICAL SPECIFICATION</b>	
<b>TITLE:</b> <b>UL INSTALLATION INSTRUCTION &amp; MAINTENANCE MANUAL FOR THE CRYSTALLINE SOLAR PHOTOVOLTAIC MODULE</b>	<b>SPEC. NO.:</b>	<b>CNPV-PS-M-S0010</b>	
	<b>REVISION:</b>	<b>F</b>	
	<b>EFFECTIVE DATE:</b>	<b>Jan. 2010</b>	
<b>AUTHOR(S):</b>	<b>B V Chaudary</b>		Page 5 of 12

## 10. BYPASS DIODES AND BLOCKING DIODES

Partial shading of an individual Module can cause a reverse voltage across the shaded SPV Module. Current is then forced through the shaded area by the other Modules.

When a bypass diode is wired in parallel with the series string, the forced current will flow through the diode and bypass the shaded SPV Module, thereby minimizing Module heating and array current losses.

In system utilizing a battery, blocking diodes are typically placed between the battery and the SPV Module output to prevent battery discharge at night.

Diodes that are used as blocking diodes must: Have a Rated Average Forward Current [ $I_{F(AV)}$ ] **above** maximum system current at highest Module operating temperature. Have a Rated Repetitive Peak Reverse Voltage [ $V_{RRM}$ ] **above** maximum system voltage at lowest Module operating temperature.

## 11. WARNING AND NOTES

The SPV Modules generate electricity when exposed to light. Array of many Modules can cause lethal electrical shock and burn hazards. Only authorized and trained personnel should have access to these Modules. To reduce the risk of electrical shock or burns, modules maybe covered with an opaque material during installation to avoid electrical shocks or burns. Do not touch live terminals with bare hands. Use insulated tools for electrical connections.

Use appropriate methods to mount SPV Modules. Fall of Modules from high place will cause death, injury or damage. The SPV Module has a pair of male and female waterproof connectors. For a series electrical connection, connect positive (+) connector of first SPV Module to negative (-) connector of the following Module.

Do not short the positive and the negative. Do not disconnect under load. Be sure connectors have no gap between the insulators. In case there is a gap, a fire and/or an electrical shock may occur.

### NOTES:

(1) Artificially concentrated sunlight shall not be directed on the SPV Module. The rated electrical characteristics are within 10 percent of measured values under standard test conditions (Irradiance of 1000W/m<sup>2</sup>, AM 1.5 spectrum, and cell temperature of 25°C).

(2) Under normal conditions, a solar photovoltaic Module is likely to experience conditions that produce more current and/or voltage than reported at standard test conditions. Accordingly the value of Isc and Voc marked on this Module should be multiplied by a factor of 1.25 when determining component voltage ratings, conductor current ratings, fuse sizes, and sizes of controls connected to the SPV output. Refer to Section 690-8 of the National Electrical Code for an additional multiplying factor of 1.25 which may also be applicable.

(3) The installation in Canada shall be in accordance with CSA C22.1, Safety Standard for Electrical Installations, Canadian Electrical Code, Part 1.

(4) Details for wiring in accordance with the NEC.

(5) If you install modules in parallel electrically, each module (or series string of modules so connected) shall be provided with the maximum series fuse as specified.

		<b>TECHINICAL SPECIFICATION</b>
<b>TITLE:</b> <b>UL INSTALLATION INSTRUCTION &amp; MAINTENANCE MANUAL FOR THE CRYSTALLINE SOLAR PHOTOVOLTAIC MODULE</b>	<b>SPEC. NO.:</b>	<b>CNPV-PS-M-S0010</b>
	<b>REVISION:</b>	<b>F</b>
	<b>EFFECTIVE DATE:</b>	<b>Jan. 2010</b>
<b>AUTHOR(S):</b>	<b>B V Chaudary</b>	Page 6 of 12

## 12. MODULE WIRING

Each Module has two #12 AWG type standard 90°C sunlight resistant output cables each terminated with plug & ply connectors. This cable is suitable for applications where wiring is exposed to the direct rays of the Sun. We recommend that all wiring and electrical connections comply with the National Electrical Code (NEC).

For field connections, use the minimum No. #12 AWG copper wires insulated for a minimum of 90°C and Sunlight resistant as well. The minimum and maximum outer cable diameters of the cable are 5 to 7mm. Refer to table 1 for the maximum electrical rating of series fuse.

## 13. TYPE OF PRODUCT APPLICATION

“The modules are qualified for application class A: Hazardous voltage (IEC61730: higher than 50V DC; EN61730: higher than 120V), hazardous power applications (higher than 240W) where general contract access is anticipated (Modules qualified for safety through EN IEC61730-1 and EN IEC61730-2 within this application class are considered to meet the requirements for Safety class II)”

## 14. MAINTENANCE

Under most weather conditions, normal rainfall is sufficient to keep the SPV Module glass surface clean. If dirt build-up becomes excessive, clean the glass only with a soft cloth using mild detergent and water. USE CAUTION WHEN CLEANING THE BACK SURFACE OF THE MODULE TO AVOID PENETRATING THE SUBSTRATE MATERIALS. SPV Modules that are mounted flat (0° tilt angle) should be cleaned more often, as they will not "self clean" as effectively as Modules mounted at a 15° tilt or greater. Once a year, check the tightness of terminal screws and the general condition of the wiring. Also, check to be sure that mounting hardware is tight. Loose connections will result in damage for array. Changed SPV Module must be the same kind and type. Do not touch live parts of cables and connectors. Use appropriate safety equipment (insulated tools, insulating gloves, etc.), when touching them.

Cover the front surface of the SPV Module by an opaque or other material when repairing. The SPV Modules when exposed to sunlight generate high voltage and are dangerous.

## 15. SPECIFICATIONS:

See Table1

### Notes

1. Standard Test Condition(STC) of Irradiance of 1000W/m<sup>2</sup>, AM1.5 Solar Spectrum & 25°C cell temperature
2. Nominal Operating Cell Temperature (NOCT): 45±2°C
3. The tolerance of Voltage and Current within ±10%
4. Temperature coefficient of Current is 0.05%/°K
5. Temperature coefficient of Voltage is -0.35%/°K
6. See SPV Module drawing for mounting and grounding holes locations

		<b>TECHINICAL SPECIFICATION</b>	
<b>TITLE:</b> UL INSTALLATION INSTRUCTION & MAINTENANCE MANUAL FOR THE CRYSTALLINE SOLAR PHOTOVOLTAIC MODULE		<b>SPEC. NO.:</b>	CNPV-PS-M-S0010
		<b>REVISION:</b>	F
		<b>EFFECTIVE DATE:</b>	Jan. 2010
<b>AUTHOR(S):</b>	B V Chaudary	Page 7 of 12	

Table 1: Electrical and Mechanical Specifications.

Module Series	Model	Dimensions (mm)	Weight (kg)	Electrical Performance @ STC					Max-System Voltage (VDC)	Max-Series Fuse (A)			
				P <sub>max</sub> (W)	V <sub>Pm</sub> (V)	I <sub>Pm</sub> (A)	V <sub>oc</sub> (V)	I <sub>sc</sub> (A)					
72pcs 125×125mm SPV Module (Mono-Crystalline Silicon)	CNPV-160M	1581×809×40	15.5	160	34.5	4.65	43.0	5.15	IEC61215/IEC61730:1000VDC & UL1703: 600VDC	9.0			
	CNPV-165M			165	35.2	4.70	43.4	5.20					
	CNPV-170M			170	35.8	4.75	43.8	5.25					
	CNPV-175M			175	36.6	4.80	44.2	5.30					
	CNPV-180M			180	37.2	4.85	44.6	5.35					
	CNPV-185M			185	37.8	4.90	45.0	5.40					
	CNPV-190M			190	37.8	5.05	45.1	5.55					
	CNPV-195M			195	37.9	5.15	45.2	5.60					
	CNPV-200M			200	38.0	5.25	45.3	5.65					
54pcs 156×156mm SPV Module (Mono-Crystalline Silicon)	CNPV-205M-54	1482×992×46	18.0	205	27.2	7.55	33.2	8.20		IEC61215/IEC61730:1000VDC & UL1703: 600VDC	14.0		
	CNPV-210M-54			210	27.4	7.65	33.4	8.30					
	CNPV-215M-54			215	27.6	7.80	33.6	8.40					
54pcs 156×156mm SPV Module (Poly-Crystalline Silicon)	CNPV-200P-54	1482×992×46	18.0	200	26.7	7.50	33.1	8.15			IEC61215/IEC61730:1000VDC & UL1703: 600VDC	14.0	
	CNPV-205P-54			205	26.9	7.63	33.3	8.25					
	CNPV-210P-54			210	27.1	7.75	33.5	8.35					
60pcs 156×156mm SPV Module (Mono-Crystalline Silicon)	CNPV-200M	1650×992×46	19.5	200	28.6	7.00	36.0	7.60				IEC61215/IEC61730:1000VDC & UL1703: 600VDC	14.0
	CNPV-205M			205	28.9	7.10	36.2	7.70					
	CNPV-210M			210	29.2	7.20	36.4	7.80					
	CNPV-215M			215	29.5	7.30	36.6	7.90					
	CNPV-220M			220	29.8	7.40	36.8	8.00					
	CNPV-225M			225	30.0	7.50	37.0	8.10					
	CNPV-230M			230	30.3	7.60	37.2	8.20					
	CNPV-235M			235	30.7	7.65	37.6	8.30					
	CNPV-240M			240	30.8	7.80	37.6	8.40					
	CNPV-245M			245	30.9	7.93	37.7	8.50					
	CNPV-250M			250	31.0	8.00	37.8	8.60					
60pcs 156×156mm SPV Module (Poly-Crystalline Silicon)	CNPV-190P	1650×992×46	19.5	190	28.0	6.80	35.6	7.40	IEC61215/IEC61730:1000VDC & UL1703: 600VDC				14.0
	CNPV-195P			195	28.3	6.90	35.8	7.50					
	CNPV-200P			200	28.6	7.00	36.0	7.60					
	CNPV-205P			205	28.9	7.10	36.2	7.70					
	CNPV-210P			210	29.2	7.20	36.4	7.80					
	CNPV-215P			215	29.5	7.30	36.6	7.90					
	CNPV-220P			220	29.8	7.40	36.8	8.00					
	CNPV-225P			225	30.1	7.50	37.0	8.10					
	CNPV-230P			230	30.3	7.60	37.2	8.20					
	CNPV-235P			235	30.5	7.70	37.3	8.30					
	CNPV-240P			240	30.8	7.80	37.4	8.40					



## TECHINICAL SPECIFICATION

**TITLE:**  
**UL INSTALLATION INSTRUCTION & MAINTENANCE MANUAL FOR THE CRYSTALLINE SOLAR PHOTOVOLTAIC MODULE**

**SPEC. NO.:**

**CNPV-PS-M-S0010**

**REVISION:**

**F**

**EFFECTIVE DATE:**

**Jan. 2010**

**AUTHOR(S):**

**B V Chaudary**

Page 8 of 12

Module Series	Model	Dimensions (mm)	Weight (kg)	Electrical Performance @ STC					Max-System Voltage (VDC)	Max-Series Fuse (A)
72pcs 156x156mm SPV Module (Mono-Crystalline Silicon)	CNPV-260M	1965x992x46	25.0	260	36.1	7.20	43.4	7.80	IEC61215/IEC61730:1000VDC & UL1703: 600VDC	14.0
	CNPV-265M			265	36.3	7.30	43.6	7.90		
	CNPV-270M			270	36.5	7.40	43.8	8.00		
	CNPV-275M			275	36.7	7.50	44.0	8.10		
	CNPV-280M			280	36.9	7.60	44.2	8.20		
	CNPV-285M			285	37.0	7.70	44.4	8.30		
	CNPV-290M			290	37.2	7.80	44.6	8.40		
	CNPV-295M			295	37.3	7.90	44.8	8.50		
	CNPV-300M			300	37.5	8.00	45.0	8.60		
	72pcs 156x156mm SPV Module (Poly-Crystalline Silicon)			CNPV-250P	1965x992x46	25.0	250	35.8		
CNPV-255P		255	36.0	7.10			43.6	7.70		
CNPV-260P		260	36.2	7.20			43.8	7.80		
CNPV-265P		265	36.4	7.30			44.0	7.90		
CNPV-270P		270	36.6	7.40			44.2	8.00		
CNPV-275P		275	36.7	7.50			44.4	8.10		
CNPV-280P		280	36.9	7.60			44.6	8.20		
CNPV-285P		285	37.1	7.70			44.8	8.30		
CNPV-290P		290	37.2	7.80			45.0	8.40		

**TITLE:**  
**UL INSTALLATION INSTRUCTION & MAINTENANCE MANUAL FOR THE CRYSTALLINE SOLAR PHOTOVOLTAIC MODULE**

**SPEC. NO.:**

**CNPV-PS-M-S0010**

**REVISION:**

**F**

**EFFECTIVE DATE:**

**Jan. 2010**

**AUTHOR(S):** B V Chaudary

Page 9 of 12

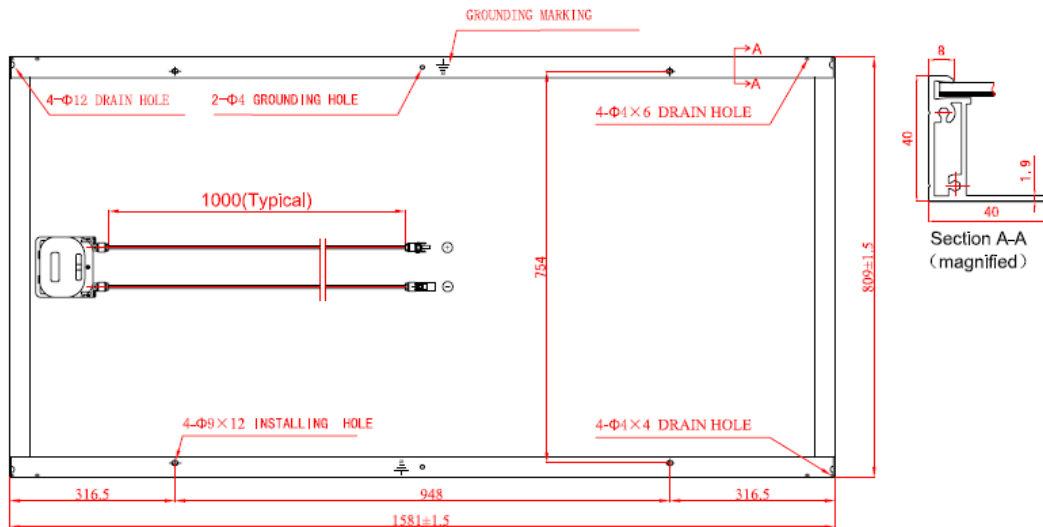

**Drawing 1 Back View of 6\*12-125mm- 72cell SPV Module**

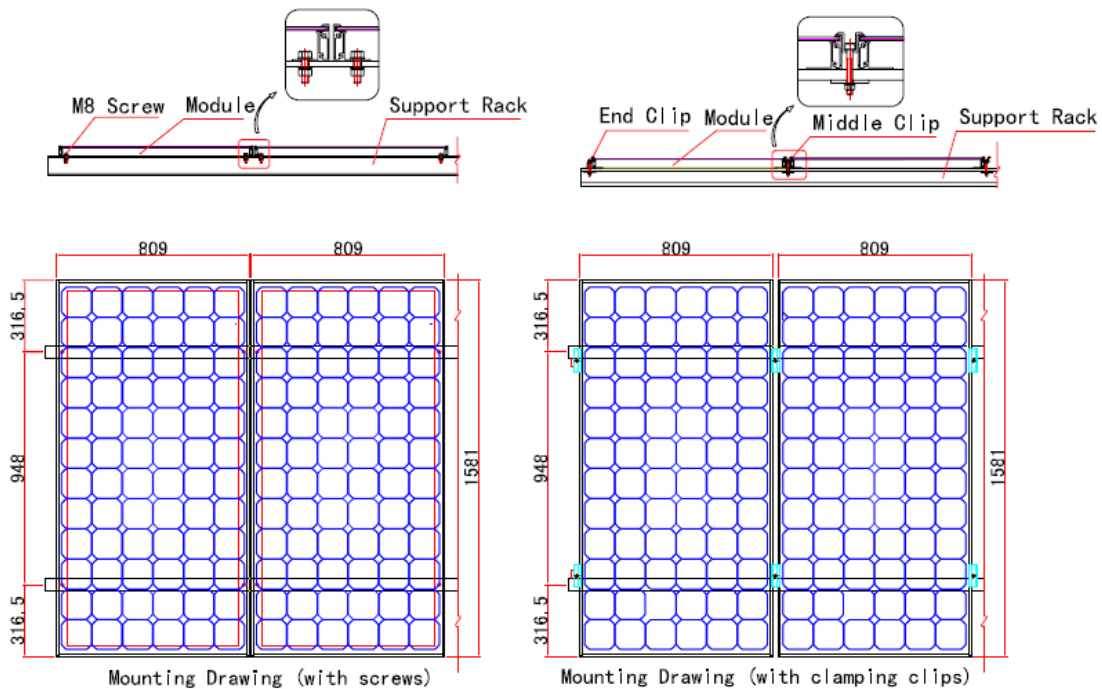

**Drawing 2 Mounting Drawing for 6\*12-125x125mm 72cell SPV Module (with clamping clips and screws)**

**TITLE:**  
**UL INSTALLATION INSTRUCTION & MAINTENANCE MANUAL FOR THE CRYSTALLINE SOLAR PHOTOVOLTAIC MODULE**

**SPEC. NO.:** CNPV-PS-M-S0010

**REVISION:** F

**EFFECTIVE DATE:** Jan. 2010

**AUTHOR(S):** B V Chaudary

Page 10 of 12

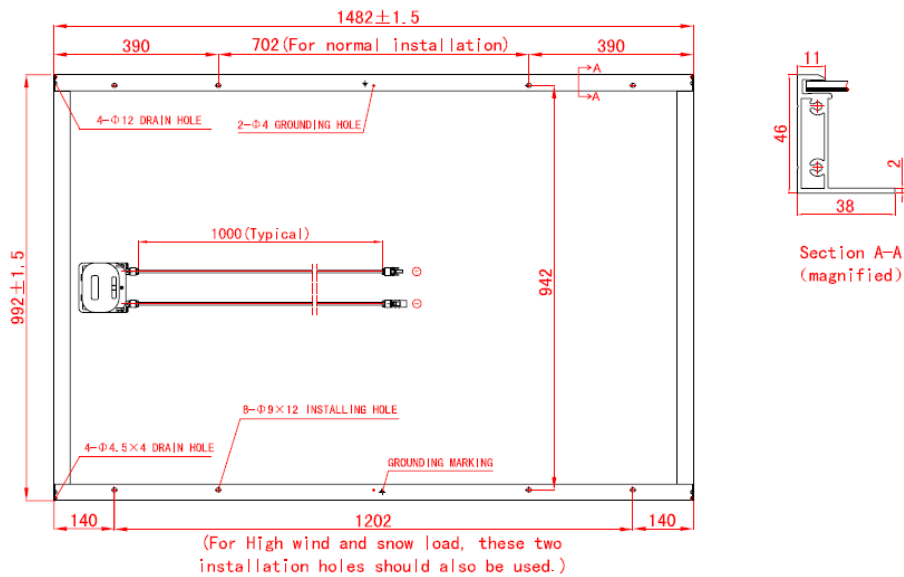

**Drawing 3 Back View of 6\*9-156x156mm 54cell SPV Module**

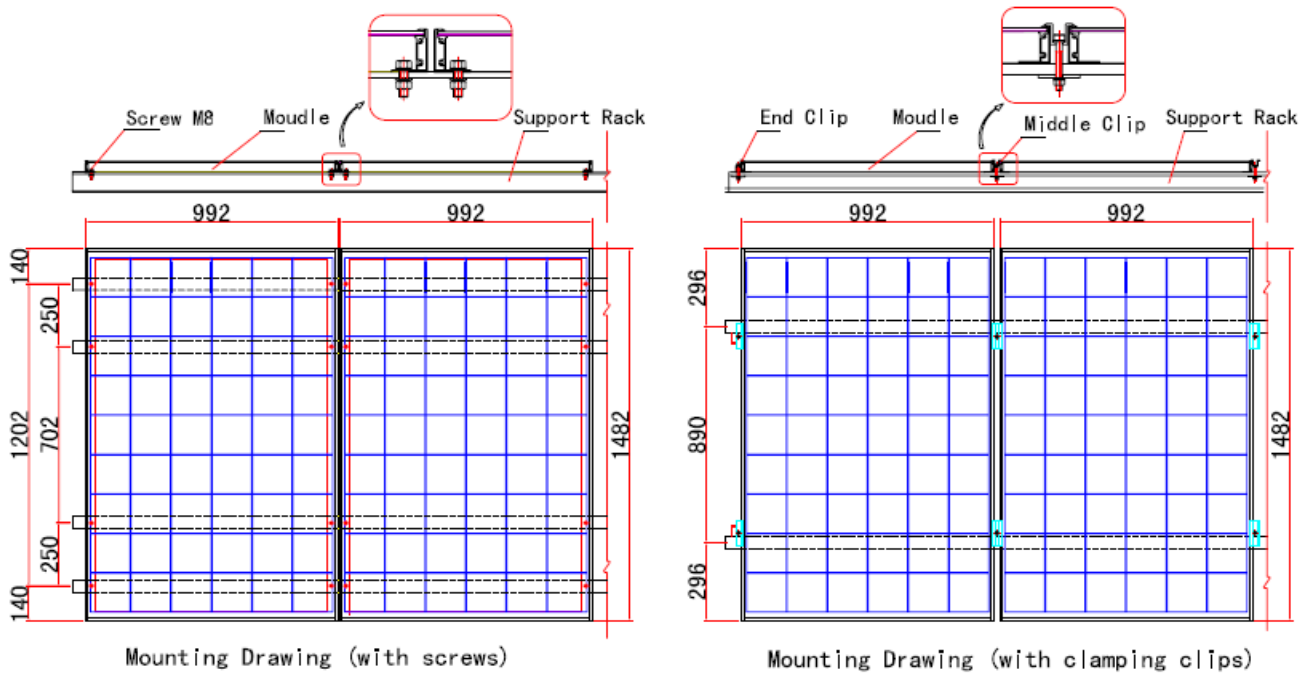

**Drawing 4 Mounting Drawing for 6\*9-156x156mm 54cell SPV Module (with clamping clips and screws)**

**TITLE:**  
**UL INSTALLATION INSTRUCTION & MAINTENANCE MANUAL FOR THE CRYSTALLINE SOLAR PHOTOVOLTAIC MODULE**

**SPEC. NO.:**

**CNPV-PS-M-S0010**

**REVISION:**

**F**

**EFFECTIVE DATE:**

**Jan. 2010**

**AUTHOR(S):** B V Chaudary

Page 11 of 12

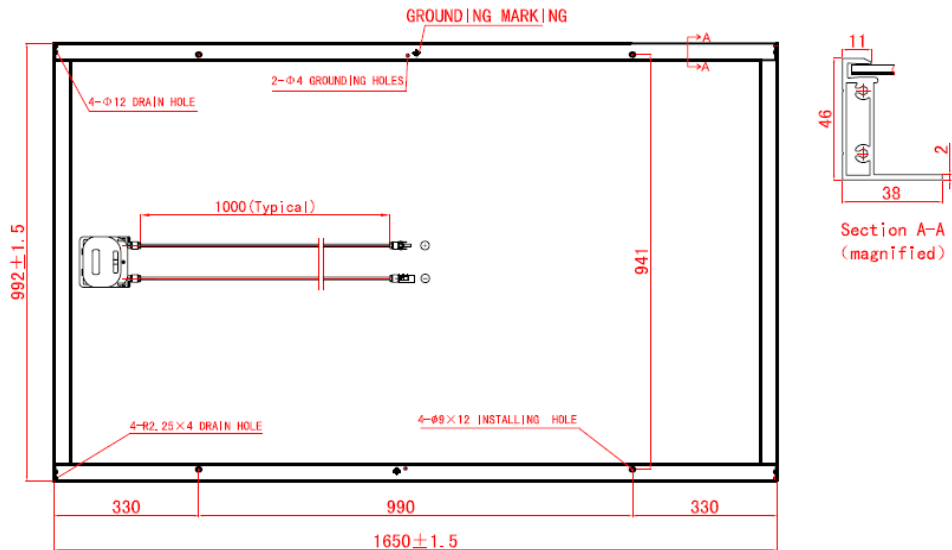

**Drawing 5 Back View of 6\*10-156x156mm 60cell SPV Module**

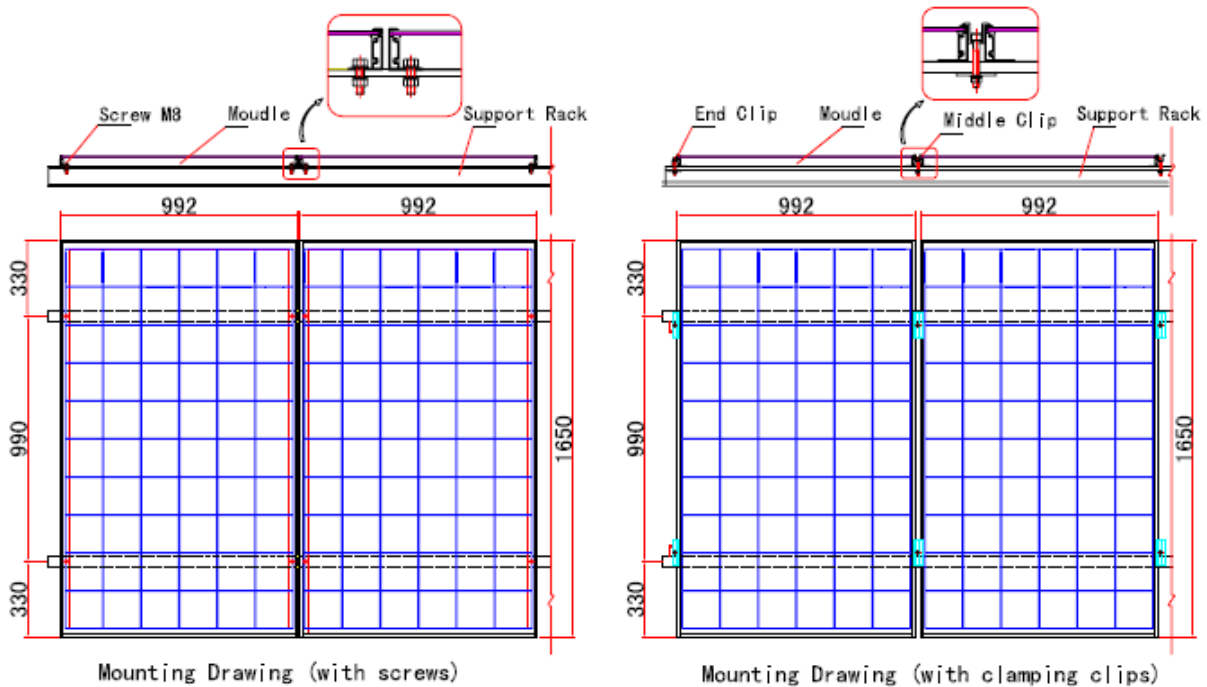

**Drawing 6 Mounting Drawing for 6\*10-156x156mm 60cell SPV Module (with clamping clips and screws)**

**TITLE:**  
**UL INSTALLATION INSTRUCTION & MAINTENANCE MANUAL FOR THE CRYSTALLINE SOLAR PHOTOVOLTAIC MODULE**

**SPEC. NO.:**

**CNPV-PS-M-S0010**

**REVISION:**

**F**

**EFFECTIVE DATE:**

**Jan. 2010**

**AUTHOR(S):** B V Chaudary

Page 12 of 12

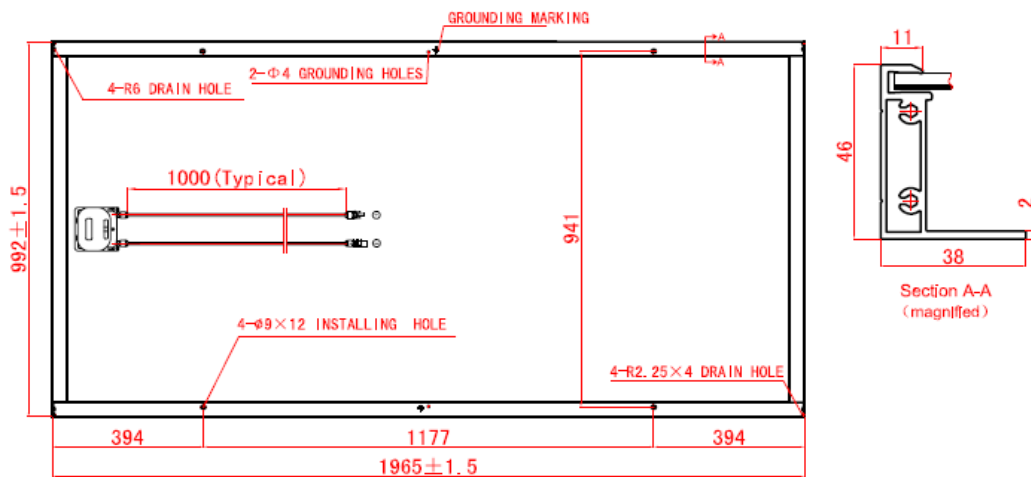

**Drawing 7 Back View of 6\*12-156x156mm 72cell SPV Module**

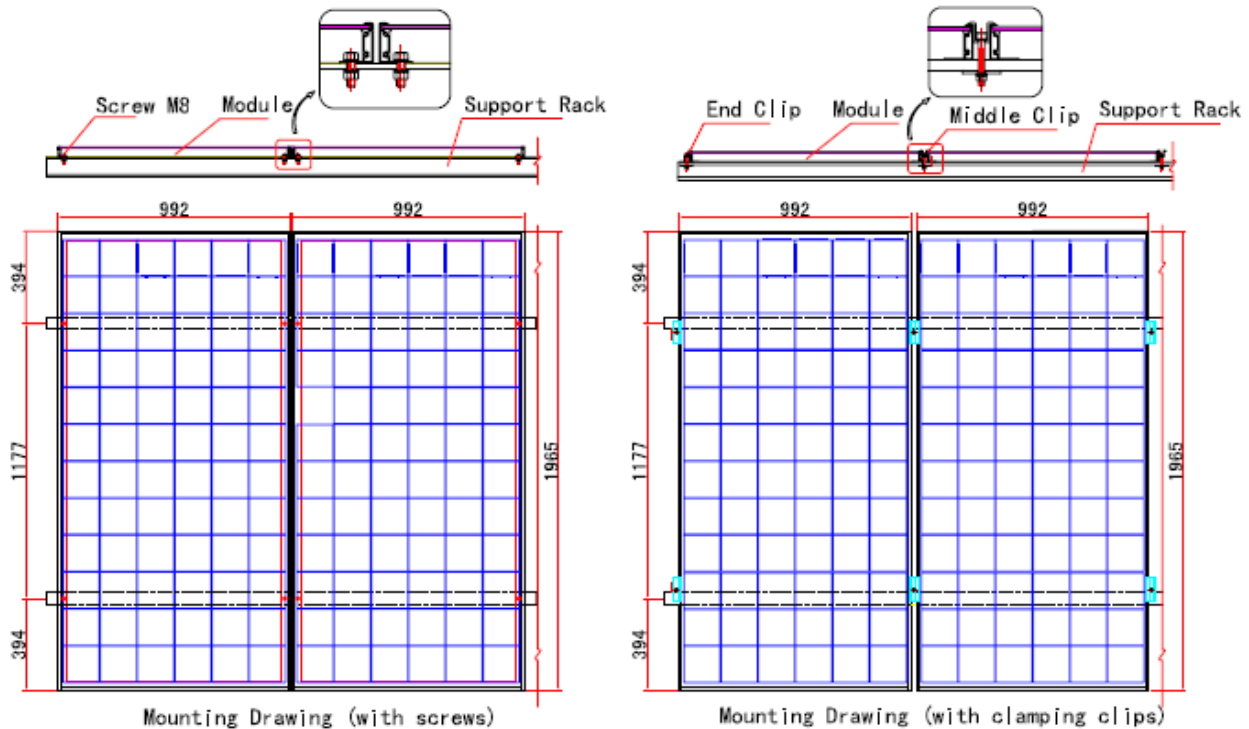

**Drawing 8 Mounting Drawing for 6\*12-156x156mm 72cell SPV Module (with clamping clips and screws)**